



# Coms Cabling Regulations & Standards Update

Published by Australian Cabler Registration Service (ACRS) in the interests of the cabling industry and for the benefit of registration cabler and others that have a need for this information

July 2004

Issue 4

**T**he response to the feedback was very encouraging and we will endeavour to address those issues you have raised in future editions.

Those cablers who have been unable to get hold of a copy through their own company can pick one up from Wholesalers or contact ACRS and we will mail you a copy.

**Standards Update**  
By  
Standards Australia

## Cabling Standards Continue to Roll Out

**T**he Joint Standards Australia / Standards New Zealand committee CT-001 *Communications Cabling* has recently released for publication a revised Standard directly impinging on the cabling industry.

**AS/NZS 3085.1** Telecommunications installations-Administration of communications cabling systems

The objective of this Standard is to provide designers and specifiers, building owners and managers, and those who are required to meet cabling requirements (e.g. installers), with a standard format for specifying required cabling in tender and construction drawings, and basic specifications for identification and recording of components at the time of installation to aid in administration of application, maintenance and reconfiguration (if

necessary) of telecommunications cabling infrastructure.

Adoption of this Standard will benefit architects, consultants, engineers, building owners and managers in the following respects:

(a) Facilitate standard methods for specifying, recording and interpreting plant by all staff and contractors.

(b) Allow single person or single contractor dependencies to be avoided.

(c) Facilitate planning and administration by remote staff such as information systems administrators, centralized help desks, or specialist consultants.

(d) Increase the speed of network troubleshooting and reduce down-time.

(e) Allow rapid identification and restoration of services after major building events, e.g. fire, flood or vandalism damage.

(f) Provide backup records allowing labels on plant to be restored if removed or damaged.

**Technical**  
By  
Milcom Communications P /L

## Structured cabling systems as per AS3080 - Horizontal and Backbone cabling (figs.1 & 2)

Unlike horizontal, in the backbone we can use, UTP, STP, Coaxial and Fibre. In practical terms, we use UTP and Fibre. UTP is used for telephony and fibre for data. The



standard provides details as to the maximum distance that any of the media types can be used for. UTP can be installed to a maximum distance of 800 meters. Fibre on the other hand can go to a maximum distance of 2,000 meters.

### The changes are the testing requirements

So the cabling standards to which we finally use the Cat 5, 6, 7 or anything that is foreseeable in the future does not change. What changes is the capacity of the cable which means the testing requirements.

So what is the capacity of the cable? The cable is manufactured to be technology or applications independent. That is, you can run any type of signal as long as it fits into the capacity of the cable.

The capacity of the cable is generally speaking measured in terms of its bandwidth. Bandwidth is the frequency range that can be supported on the cable. Let's look at the cable types to date.

Category	Capacity in MHz
Category 3	16
Category 4	20
Category 5	100

You can equate this to the number of lanes on a road. We could say that Cat 3 is equivalent to 16 lanes whilst Cat 5 is equivalent to 100 lanes. On top of the number of lanes, the road must be flat, no hills. This is important because you want to know exactly how much fuel you will use. In electronics we want to know how big the signal has to be to make sure by the time it gets to the other end, it can still be recognised. We also need to know what is the maximum size signal we can send to make sure that we do not interfere with other users.

So when you look at testing of the above you can do some basic testing to ensure the cable plant will support the capacity. These tests were initially:

- Wire map
- ♦ Length

- ♦ Attenuation
- ♦ Near End Cross Talk (NEXT)

But like always what we really want to know is what is the maximum speed we can get to on the road, we want to push ourselves to the limit. To do this, additional testing has been introduced so we can get a better description of the road, these test are:

- ♦ Far End Crosstalk (FEXT)
- ♦ Power Sum NEXT
- ♦ Equal Level FEXT (ELFEXT)
- ♦ Skew delay
- ♦ Propagation delay

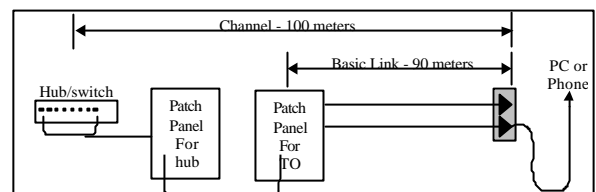

Fig. 1- Horizontal cabling

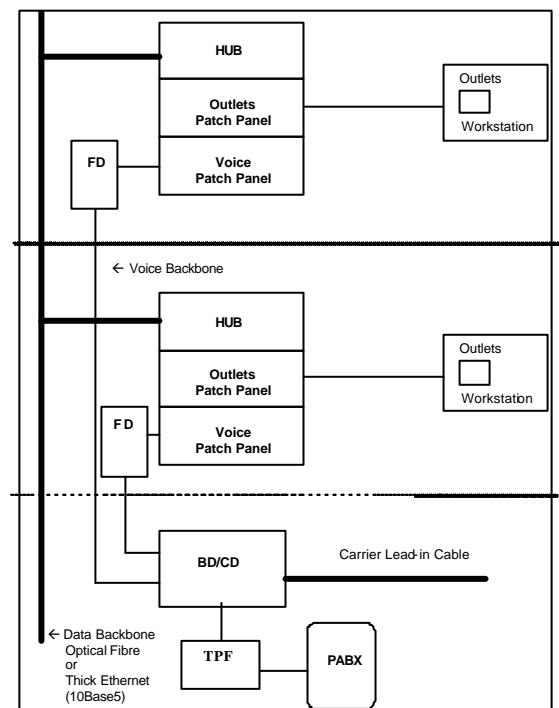

Fig. 2 -Backbone cabling

We will pursue this subject in further issues .

## Australian Cabler Registration Service

Level 3, 100 Dorcas St, South Melbourne Vic. 3205

Tel: 1300 667 771 email: mishele@neca.asn.au

ACRS



**Australian Cabler Registration Service**  
Level 3, 100 Dorcas St, South Melbourne Vic. 3205  
Tel: 1300 667 771 email: [mishele@neca.asn.au](mailto:mishele@neca.asn.au)